

Rapid Manufacturing with carbon reinforced plastics: applications for motor sport, aerospace and automotive small lot production parts

Ing. Franco Cevolini

CRP Technology srl

Address: Via Cesare della Chiesa 21/23, 41100 Modena, Italy

Phone: 0039059 821135

Fax: 0039 059 822071

E-mail: lcevolini@crptechnology

Abstract

From concept design and modelling to functional testing models, high-end prototypes and small lot production parts. Quality and repeatability closer to production suppliers but within ridiculously short delivery time. These are the needs of motor sport, aerospace and automotive sectors.

Materials manufacturers worked hard to improve parts properties and quality, machines producers are trying to obtain repeatability.

The latest carbon fibre filled material for laser sintering technology, branded WINDFORM®XT, has paved the road that others are trying to pursue.

Penske Racing, Red Bull Racing, VM Motori S.p.A., Lamborghini and an aerospace market supplier help us to understand what is the difference between WINDFORM®XT applied to laser sintering and previous technology.

Introduction

Nowadays, customers look for performance, quality and repeatability close to those

assured by standard production suppliers but within ridiculously short delivery time.

The Rapid Prototyping techniques, that in the early days were applied mainly for concept design and modelling, now are required to realize production parts, or at least really functional prototypes.

Parts performance should therefore allow to jump directly from 3D CAD drawings to functional models and finished parts, in order to shorten lead-times: engineers just have to think about the loadings and final product performance, no shape or manufacturing limits, no long post processing time, just a CAD file, a STL file and a finished part.

Materials manufacturers are working hard to improve parts' properties and quality, whilst machines producers are trying to obtain repeatability, and now it is almost possible to use layer manufacturing techniques also for high-end prototypes and small lot production parts.

Customers' enquiries

Looking at aerospace, motor sport and automotive sectors, the requirements that become more and more decisive are exactly high performance, high quality and short time.

High quality is already reached by CRP thanks to the long experience alongside the greatest Italian and European automotive companies.

The latest carbon fibre filled material for laser sintering technology, branded WINDFORM®XT and produced by CRP Technology, complies in fact the last requirements for end-users and service providers looking for Rapid Manufacturing: high mechanical and thermal properties allow to shift from simple concept models to high-end prototypes and production parts, while the Quality Politics is applied in order to hold the performance closer to production technologies (for powders certification: Certificate of Conformity regulated by the EN 10204: 2005 Type 3.1, that means that tests on powders are made by an independent laboratory; for sintered material certification: each batch is characterized by tests on the sintered bars, done by external and certified laboratories).

Concerning high performance a curious test published by CRP can give an idea of WINDFORM®XT's one.

In a comparison between WINDFORM®XT and PA6 BG-35, a high performance material for injection moulding used for production of the final parts for Automotive Industry, an external lab discovered a behavior completely different from all other materials used with Rapid Prototyping techniques. Around "top head engine area" temperature range (value from 80 deg C to 140 deg C) WINDFORM®XT has a stable evolution and predictable in advance, exactly like the injected test bars.

In particular, there's a quite slow decreasing of the tensile strength value between 90°C and 120°C and at 120°C the value is the same as that pure PA12 at 20°C; in the same ΔT the modulus has almost no decrease and at 120°C it is almost two times stiffer than standard pure PA12 at 20°C.

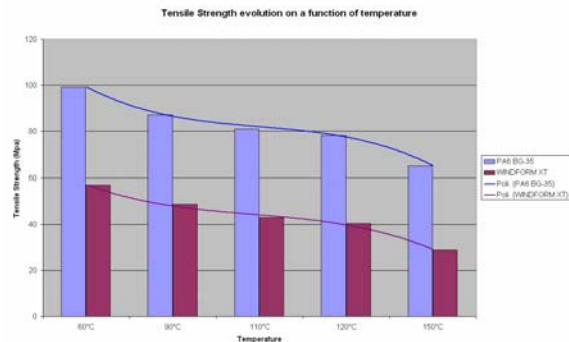

Concerning short time, the most sensible market is F1.

In F1, in fact, the main goal is to reduce the time to deliver as many design iterations as possible. Steve Nevey (RED BULL Racing) explained: "A component "not making it onto the car" for the next race can mean the loss of fractions of a second per lap and consequently maybe even forfeiting a podium finish!

RP has been an integral part of the process for delivering design iterations to the team's wind tunnel, where a half-scale car is continuously tested in as many aerodynamic configurations as time permits. And then, the inevitable question — can you make parts that go on the actual car? The advantages would be immense, if we could take that precious next step."

So it's not by chance that almost all F1 teams chose to test WINDFORM® XT parts both for wind tunnel and on track applications, and are using it for both these applications.

Those F1 teams can in fact race several GPs with on their cars many parts made by RP, such as air/fluid ducts, intakes, flaps, electronics boxes, fuel chambers, fuel ducts, water pump cover.

For wind-tunnel assemblies usually they ask for sidepods, air/fluid box for flow tests, all kinds of air intakes and exits, flaps and ducts.

Motorsport Case study: Red Bull Racing, F1 team

ON TRACK WITH RAPID MANUFACTURING AT RED BULL F1

At the TCT 2006 Conference Mr. Steve Nevey, Red Bull Racing Business Development Manager, has taken part with references to WINDFORM® XT use in Red Bull Racing. Here the report.

After a brief introduction on RBR business, Steve spent nice words on partnership with CRP and in particular on cooperation between RBR aerodynamic Dept. and CRP RP Dept.

There are still some needs to be satisfied, but CRP will do her best to make this job too as soon as possible.

In brief, after underlining the main challenges they have to face every day, that are Most effect use of time, As many design iterations as possible, Focus on ROI and Best spend for limited resources, he focused on aerodynamics area.

There are 3 main following steps to develop the car performance:

1) CFD

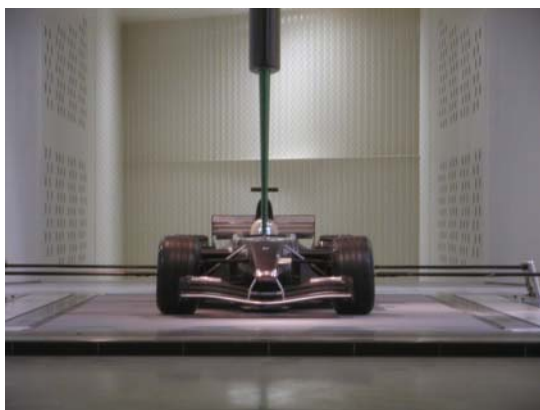

2) wind tunnel test

3) race car test

Wind tunnel model development during last 10 years:

- Aim is to test as many iterations as possible
- Bottleneck was model shop physically making parts (long time and high costs)
- SLA with clear resin had been used for wind tunnel the first time 6 years ago
- Parts were brittle and unstable: the available resins were too weak.
- About 4 years ago Ceramic filled SLA had been tested: higher mechanical properties, but still very fragile, photo and humidity sensible, heavy parts.
- 1 year ago: Metal plated SLA, increased mechanical properties but very high weight
- Since few years ago SLS with WINDFORM® materials, and last year 'till nowadays high usage of WINDFORM® XT.

Today RBR is using a lot WINDFORM® materials both for wind tunnel model and for the racing car, but one of the key parts that still has some problems for RP processes is the brake air intake: close to the wheel upright, it cools the brake system in order to allow a good and continuous brake performance. SLA materials had been tested but the mechanical properties required were too high: the duct broke just outside the pit lane, at the first track bump. WINDFORM® XT resulted perfect during the test on track, mechanical properties were fine and it never broke. But the problem is the temperature: until mechanics blow cold air inside the duct, when the car is back to the pit lane box, and during the track laps, the duct works perfectly. But after the warm up lap, on the race day, while cars are waiting for the green light, on the starting grid, with no possibility to blow cold air inside, the temperatures increase too much and the Nylon base (base of WINDFORM® XT too) collapses.



So the request now for those parts is a hi-temperature material, that still is not available on the market. In the meantime F1 teams will have to continue to use carbon laminated and moulds for them. On the other side there are many “cold” parts made by WINDFORM® XT on the F1 car that have no problem at all and can race all the GP weekend.



Next step RBR and all F1 teams are so waiting for is the direct metal deposition or sintering, in order to design parts without manufacturing constraints; make quick design modifications during the season, such as to change the suspension attack on wheel uprights to increase aerodynamics performance or add ribs to increase stiffness and reliability; part repairs.

Of course what is required is the direct sintering of composite metals or very high performance alloys.

Motorsport Case study: Penske racing

PRACTICAL ADVANTAGE OF WINDFORM® XT: WINDTUNNEL REPEATIBILITY

An other great advantage of the latest WINDFORM® family material, XT spec, is described here below:

Currently used in Windtunnel, component made from RP technology in WINDFORM® XT has been directly characterized by comparison with similar component made from carbon fibre.

In this following case, component made was a large part of the car defined as a fender fitted on a Wind tunnel model of Dodge Charger currently racing in the Nextel Cup. Due to his position, the fender is defined as sensitive part with important effect on the drag (C_x), lift (C_z) and balance of the car.



During windtunnel run, as usually a map of various ride height with each of these component, the carbon fibre one then the WINDFORM® XT one, and standard aero parameters have been measured on the model, drag, lift (= downforce) and balance allowing full post session analyse for others aero parameter like efficiency.

For more indication, baseline was made with carbon fibre fender, and aero map was defined over 7 reference ride heights.

Based on the average values, data show result that was clearly within the repeatability range affecting each windtunnel. For obvious confidentiality reason, direct WT datas could not be disclosed but percent error between the two component resulted as follow:

- 0.01% for the Drag
- 0.2% for the lift (= total downforce of the model)
- 0.3% for the front downforce
- 0.08% for the rear downforce

All these are error respect to overall value of the model (i.e. error of 0.2% between the two parts on the measured downforce respect to the total downforce of the car !!),

Again this result was clearly within the range defined by windtunnel and aerodynamic teams for the typical repeatability (back to back run or placement of part on the model) or overnight repeatability, and confirm stability as well as practical advantage of the WINFOFORM XT material over carbon fibre.

Aron Oakley (Penske Racing South, Inc.), explains: "The WINFOFORM® XT prototype fender worked flawlessly for our purposes. The surface was accurate and produced acceptable results when compared to the conventional carbon fibre part. The fit and finish were perfect and required very little work to fit the part to the model (just mounting screw provisions). It also significantly reduced the production time. I actually had your part a few weeks before I had the carbon fiber pieces. Typically we would have this part made in carbon which would require a CNC cut buck,

then a mold, then a part, and then finishing of the part. Or, if we needed a part fast it would be hand made from aluminum.

The quick turn around allows us to be more accurate with our changes. The part also seems to be more stable than most rapid prototype materials. The SLA parts seem to keep "growing" over time.

The only drawback to the process is the build size. I would have an entire body made from WINFOFORM® XT if the build volume was larger!

CRP was able to significantly reduce the production time required for wind tunnel test parts allowing us to test more accurately faster."

Automotive Case study: VM Motori SpA

INTAKE MANIFOLD MADE IN WINFOFORM® XT:

Engine RA420DH6 – Turbo Diesel Common Rail 2000cc, 4 Cylinders, 16 Valves, 110 KW @ 4000 Rpm, Euro 4

The modern Turbo Diesel engines have increased their performances compared with "old" Diesel engines but recently they have to face new severe requirements regarding their emissions.

The use of EGR (Exhaust Gas Recirculation) can help engine manufacturers to keep under control the emissions in order to accomplish to the Euro 4 requirements.

In order to improve EGR system VM Motori S.p.A. (Cento, FE – ITALY) decided to test different alternative INTAKE MANIFOLDS. It could take a long projecting and engineering time, but thanks to VM engineers' good knowledge of RP techniques only few weeks were spent to reach the best performance of the manifold and the engine.

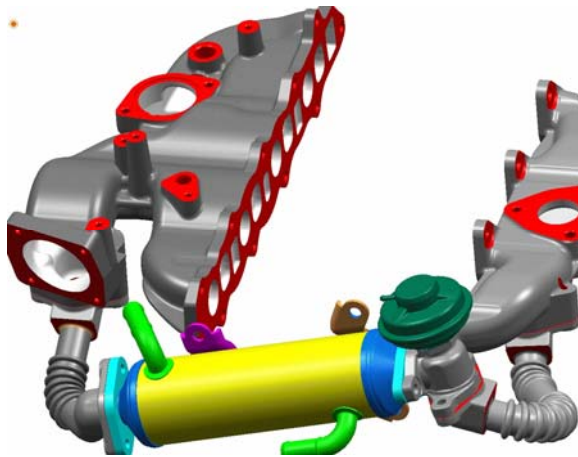

The study was performed using 3 different models, made by C.R.P. Technology in WINDFORM@XT, the latest carbon fibres filled material, for RP Laser Sintering systems. Each prototype was prepared with a typical lead-time of 2/3 days. This kind of “fast-production” was very useful for VM engineers, shortening 10 times or more the standard lead-time for this kind of product.

With the first model “V1” they realized that it was possible to use the WINDFORM@XT INTAKE MANIFOLD without any problems for their dyno tests; then they worked on other two releases, “V2” and “V3”, in order to optimize the partitioning of EGR on each cylinder, reaching the goal of a maximum of

4% of difference among the 4 cylinders (as a target for Euro 4 emission level).



Usually “standard” lead-time for a sand cast aluminium intake manifold is about 2 months. In this case they made 3 different manifolds spending only 6/9 working days. So the engineering phase that usually takes several months, lasted less than 2 weeks!

In the following table we can see some interesting data to give an idea about thermal and mechanical stress, applied to the Manifold, during normal engine use (real life engine operating points where the EGR is activated so the intake temperature is increased by mixing fresh air and hot exhaust gases).

Mode	Air Mass kg/h	EGR Rate %	T. Manifold °C	T H2O out °C	T H2O in °C
1	21	57,00%	65,80	79,20	78,70
2	56	36,00%	60,70	82,90	80,90
3	71	44,00%	60,00	81,70	80,80
4	87	22,00%	44,40	82,80	80,30
5	94	34,00%	50,40	82,60	81,30
6	105	20,00%	49,70	83,50	80,80
7	105	27,00%	71,00	84,00	81,10
8	115	26,00%	47,20	82,60	81,30
9	48	49,00%	73,50	82,40	80,90
10	123	21,70%	64,50	84,20	81,10
11	95	27,50%	60,30	83,60	81,10
12	71	34,50%	73,80	83,30	80,40
13	148	23,00%	85,40	85,40	82,00

14	176	27,00%	72,70	84,80	82,30
15	280	19,00%	91,70	87,10	83,80
16	275	20,00%	106,80	86,90	83,80
		Average:	67,37	83,56	81,29

Mode	Air Mass kg/h	EGR Rate %	T. Manifold °C	Pressure Intake Manifold BAR
Max. Output 110 KW (150 Cv) @ 4000 Rpm	550	0,00%	55,00	1,50

In the tables we can see also some values about H2O Temperature, because there's coolant fluid flowing in a duct beside the manifold, increasing its temperature (because of reduced heat exchange trough the wall) but without affecting its functionality at all.

VM engineers have done several tests, without any kind of problem. The manifold has supported also some tests lasting 2,5 hours, with the engine at the maximum output, and at the end, it was still perfect, ready to be used again.

For the production of this new Turbo Diesel Common Rail 2000 cc engine, engine designers decided to use aluminium manifolds and when they tested the first engines, they observed exactly the same results of WINDFORM®XT manifolds. It demonstrates how reliable and useful can be a study done in a incredible short time, thanks to WINDFORM®XT properties.

SIDEBAR: THE NEW CHEVROLET CAPTIVA WILL BE POWERED BY THIS ENGINE

From Chevrolet official web-site:

"From the manufacturers of the very first SUV back in 1935, Captiva is the latest in a long line of authentic sport utility vehicles offering great value for money in a stylish and practical package. Designed specifically for the European market, it will be available with front or all-wheel drive, five or seven seats and with a 2.4 litre petrol or leading-edge 2.0 litre diesel engine and will appeal to a wide range of customers. Captiva will be on sale in Europe from spring 2006."

Engine/powertrain

Type

/ 4 cyl/in line, common rail diesel

Displacement

/ 2,000 cc

Max. output

/ 110 kW/150 PS at 4,000 rpm

Automotive Case study: Lamborghini SpA

GALLARDO HEADLIGHT WASHER COVER FLAP

The collaboration with Lamborghini concerning components made with the rapid prototyping technology has found its origin in requirement of solving the problem for immediate delivery of 100 Gallardo's model to the first dealers and customers, the pre-production models.

The parts in consideration were the headlight washer cover flap.

We had to produce these components with our best performing WINDFORM® material because materials available on the market didn't reach the minimum mechanic and thermal properties: once painted the part had to be fitted directly on the car.

Considering that the Gallardo can easily reach 300 km per hour and has to resist at every climatic condition, both in winter (-20°C) and in summer (+50/60°C), rain, hail, snow or sun, the challenge was very exiting. At the beginning of 2003 the most appropriate material was the WINDFORM®PRO, aluminium and glass filled, granular and flat, for which an European Patent

Application was just logged. The part has then been produced in WINDFORM®XT, carbon fibre filled material launched on the market in December 2004: the tests made on the WINDFORM®PRO and then on the WINDFORM®XT have underlined a good increase in performance with the carbon fibre filled, so we suppose that if at that time the WINDFORM®XT had been used, the performance would have been higher. Despite this, the WINDFORM®PRO pieces didn't have any problem.

The components made from injection moulding used previously weren't suitable for this first phase.

Our relevant contact had by then explained us that for this reason the particular was still at a non definitive definition and presented some showy defects, from project and process.

Once assembled in its closed position there was an evident discontinuity with the rest of the bodywork (hood, bumper and lateral body): the external surface had a different shape in respect to the hood and front headlight's design.



Moreover, in open position, the inner structure presented some imperfections due to shrinkage of the injection moulding causing defects also on the upper external part: the design wasn't by then still not optimized for this kind of technology.

Our first goal was to guarantee the reliability of the component through an increase in thickness in some particular points; we mainly added some ribs close to the hinge of the cover flap. Consequently we corrected the shape of the external surface in cooperation with their designers, in order to gain a perfect continuity

in the area between the headlight, the hood and the headlight washer cover flap.



Once the co-engineering was finished, we realized in a couple of days a first prototype useful for the company to check resistance through several different work cycles. While this test was made we carried out a control mask that allowed us to guarantee, within defined tolerances, that the component profile would follow perfectly the specific housing. A specific dimensional inspection, made through large reference points on each piece, standard operation in Formula one, would have excessively increase each component cost, this one being a large production part.

This inspection has been made therefore only for the very initial components to be tested and for the mask.

Our new modifications had satisfied their requirement and the attention was then focused on the following problem. The original particular had a shiny black colour, similar to the headlight's one. Lamborghini's idea was to receive the particulars with already a primer on them, thus being able to paint them. We did it but their first painting test didn't come up with positive results. In fact their internal paint shop did consider the WINDFORM®PRO parts as if they were made of steel and therefore with some process at fairly too high temperature, causing deformation. Later, following our suggestion, the painting was made by a paint shop close to their

company considering the correct temperature for our material and painting result was by then excellent.

Even the scratching test, performed to test pigmentation's wear resistance in face of asperities at high speed, didn't highlight any problem.

Once performed this last test, the remaining parts were finished and the first 100 cars were delivered with WINDFORM®PRO components fitted. Thanks to the rapidity of laser sintering technology and to the material performance used for these parts, the delivery timing of the first cars were respected: in a couple of weeks the cover flap were sintered, superficially finished in order to have the minimum roughness for an excellent surfaced finish, painted and assembled on the conveyer.

Since today we didn't have any claim or any minimum problem concerning these parts.

Aerospace Case study: Maquettes, Olivier Lourdais, Olivier Coulet

COLD DUCT FAN

Among the most significant case studies, developed together with our partners, the "Mini Fan" described in this document is one of my favourite one, as we tried to choose the most suitable technology and material to push forward for this project.

We could in fact try to manufacture it with several different technologies, such as CNC machining or through casting with special metal alloys, or even laser sintering of simple PA12 or PA12 glass filled (we cooperate in fact also with some companies in France that have PA12 and have tested it for the mini-fan too), but at the end it has been really clear that WINDFORM® XT was the best choice. Let's see why.

We can think about a little fan, whose engine power is given by an electric device, instead of 2/4 strokes engine. By extrapolation, we could even call it small mono stage compressor even if in this case the static pressure increase is very low (no precise data to be released).

Now, without the classic parameters (due to confidentiality), such as efficiency or level of reaction, which permit to characterize quality of a turboshaft engine, we will try to explain the advantages of this project analyzing the data provided by our partner:

- Engine mass: 270 grams
- Nominal output power: 1000 W (Watts)
- Maxi power: 1200 W
- Current tension for power supply: 24 V
- Theoretical Tension: more or less 50 A
- Association of two 12 V lead battery would bring an enormous overall weight and not suitable with a flying equipment: the battery requested for real use could be a Lipo: lithium.
- Specific speed for the project: nominal diameter of 100 mm (98 mm included the play) at 36.000 rpm, given a speed of 184.6 m/s (664.7 km/h) at the extremity of the blade.
- Crossing section measured down to the fan:
 - Nominal diameter 100 mm giving 7854 mm²
 - Hub diameter 48 mm giving 1810 mm²
 - All this give a crossing section of 6044 mm²
- Percentage of resulted thrust in the fan and ducts:
 - without stator and with 9 or 7 blades best result was around 1 kg
 - with stator #1 and 9 blades, result was 1.4 kg
 - with modified stator and 9 blades, result was 2.2 kg
- Profile type for the blades:
 - For the fan blades: unknown but visually quite closed to aircraft wing
 - Chord 21 mm thickness 2 mm
- Angles characteristics for the blades:
 - 9 degrees at the extremity of the blades and same twist ratio to the hub
 - New fan 15 degrees
- Project conditions:

Test performed with a temperature of 20 deg Celcius
 The rig for static thrust measurement was made by a ball guide rail and a strain gauge connected to a display.

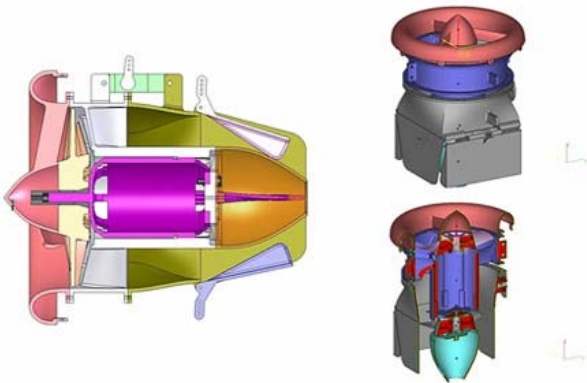
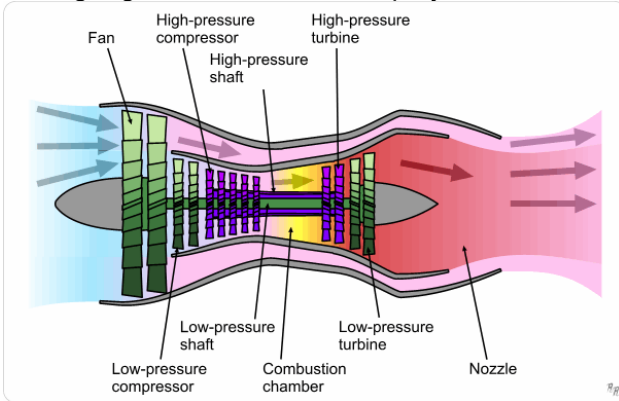

The mini-fan made from WINDFORM® XT for a fluid dynamic study is composed of a mini axial compressor fitted in a case and characterized by high stiffness values, therefore able to minimize those vibrational problems that affect prototypes made of other materials.



It is therefore called COLD DUCT FAN, because it is supplied by a small electric

engine which doesn't produce an excessive amount of heat and that stays at almost low thermal regime, it doesn't pollute, it's very easy to use (it doesn't need great open spaces for take off and landing) and can fly for several hours, depending on the technology used for the batteries.

The COLD DUCT FANS can't be visible by IR rays (IR visualize heat over certain temperatures) and if made of non metallic materials can also escape the Radars.

The project realizes a flying object mostly suitable for short and quick operation such as rapid inspections with photo cameras, illumination ...

In fact it is possible to put 3 or 4 mini fans in series with its own electric rotor connected to the same lithium battery, to allow not only the take off but also the horizontal flight.

This study can be defined as a double manufacturing: on one side a double flow turbo fan in scale and on the other a protected fan, electrically operated and power supplied by an extra-lightweight set of batteries or by solar panels positioned on a very long wing (in order to have the necessary amperage it would require 1,5 square meters of last generation solar panels).

The heart of both of these realizations is the frontal fan that, experimented in different configurations, also with high revs, almost 36000 rpm, guarantees excellent dynamic performances thanks to the use of WINDFORM® XT.

Coupling the fan to the mini double flow turbojet, you end up with the above mentioned double flow turbofan, with much higher thrust values (you can reach 6/7 Kg) but, thanks to the compressor performance, it would guarantee extremely low specific consumption values (that's why turbofans are used on commercial aircrafts).

Both in the electric and endothermic cases, the prototyped fan is particularly suitable for the movement of high technology micro aircrafts for military spying or meteorological studies. The choice falls on the electrical engine, for obvious reasons.

In the turbofan case in fact, as the compressor is characterized by such high rpms, it wouldn't even be necessary the insertion of a gear reductor between the turbine and the fan with evident advantages in weight saving for the whole propeller; on the other side it would generate too much heat and would be complicate to manage: both things are to be avoided in this present project.

Two small notes on the turbofan: it is started by an auxiliary unit and once it is at cruising rpms, it can be easily described: entering through the fan, the air is accelerated and compressed: a part of will exit without anymore cycle generating a percentage of thrust (around 35% in general); the remaining mass is introduced, usually after another couple of compression cycle in the combustion chamber. Over here the air is decelerated and undergoes a raise of temperature and pressure. It's then ducted to a turbine (whose blades are highly thermically stressed) which, rotated by the flux, takes part of the pressure energy turning it into mechanic energy, useful to make the fan rotate. The energy left is then turned into thrust in the exhaust's ducts and nozzle. Therefore the high heat would need the use of high performance alloys such as Inconel and would bring great complications for its use, with the consequent impossibility to be used without being seen by Radars and IR.

Thanks to the laser sintering technology and to the newly increased performance allowed by CRP's carbon fibre filled material, different solutions and wing profiles have been experimented to define the better set up.

In this present case, the assembly presented is a system rotor-stator with controlled directional shutters and an electric engine reduced in performance (300 rpm instead of 36 000 rpm) with transformer. The unit has been assembled in a delta structure under real operation and dynamic flight, to complement the static tests. Thanks to prototyping, our partner could make several fans with different numbers of blades and various stators, several air ducts, without needing to change angles during operation uses: fan with variable twist ratio would have

been a project much more complex and expensive.

We manufactured more than 20 turbines in PA12 and in WINDFORM® XT in order to understand which one was the best: with 3 blades, 5 blades, 7 blades, 9 blades, 11 blades, and so on.

5 axis machining would have been too expensive and too complex and we wanted to have the possibility to test the most suitable number of blades to the engine.

Then the engine has been assembled in the stator and no final adjustment was required, it seemed a perfect assembly of the other parts and very good fitting: no friction or parasitizes vibration while working, both with PA12 and WINDFORM® XT.

The number of revolutions of the engine reached is 36 000 rpm, that is extremely high for this kind of application.

The best vectorial push has been obtained at the first assembly: initially tests have been done only with the turbines (without stator, etc.) in order to find as well as possible the best one; it would seem it's the one with 7 or 9 blades; then second tests were done with the whole assembly (with stator).

- 3 blades: 600 g
- 5 blades: 850 g 1500 g with stator
- 7 blades: 1020 g
- 9 blades: 1050 g
- 11 blades: 980 g 1400 g with stator

Briefly, the parts seemed to be enough defined and rigid, having very positive matching , even with rotors in PA12.

The stator indeed has been manufactured immediately in WINDFORM® XT because it has been immediately clear that the final needed surface quality and rigidity could be obtained only with it, being so able to bear more stress too, without "pulsing" and so allowing a compression factor more reliable, constant and sure. A greater rigidity of the stator is also necessary to make of it a structural part of a delta system wing of a drone.

By the way, after some more tests we understood that also the rotor system had some reliability problems: the blades, at that high speed and compression, were changing

their inclination and shape, without being under control, and the performance factor was changing every time, depending on weather, speed, and every other possible variable. It was a dangerous situation that has been solved manufacturing the rotor in WINDFORM® XT too: the blades are now stiffer, don't change their shape and inclination while working. The performance, and so the push, is now fixed and reliable.

Only with laser sintering and carbon fiber filled WINDFORM® XT the project could be developed and tested in such a short time and with a such high performance reached.